

Manual for Owners and Skippers

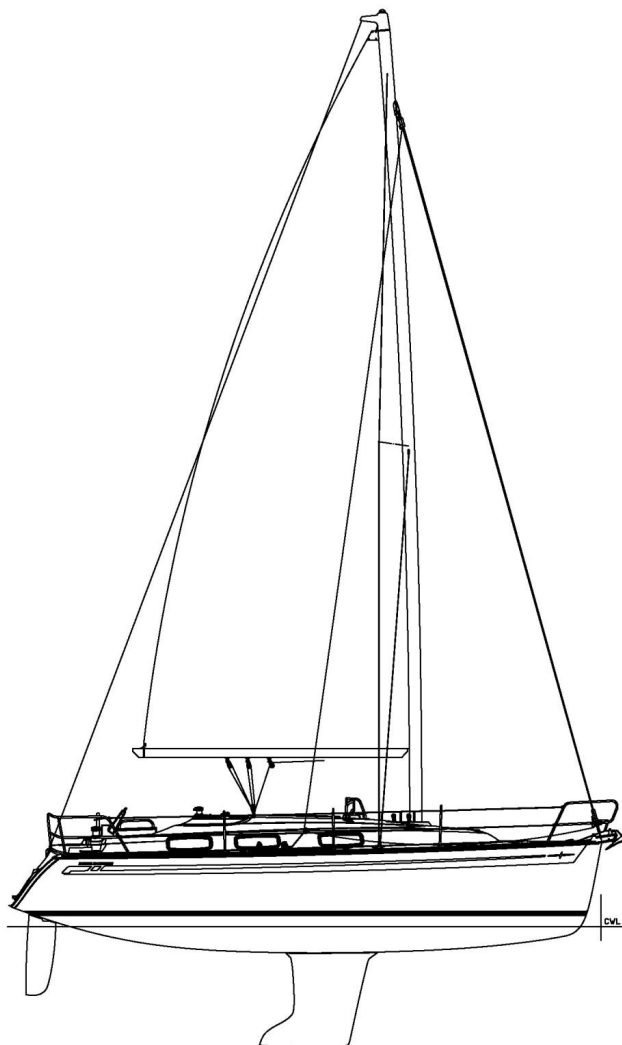

Sailing yacht „BAVARIA 30 Cruiser”



BAVARIA YACHTS

Bavaria Yachtbau GmbH • Bavariastr. 1 • D – 97232 Giebelstadt

Tel.: +49 (0) 9334 942 – 0; Fax: +49 (0)9334 942 – 116

e-mail : info @bavaria-yachtbau.com

INDEX

	page
Introduction	4
Category of design	5
Builder's plate	6
Warnings	6
Declaration of Conformity	7
<u>1. Description of the yacht</u>	11
1.1 Main particulars	11
1.1.1 Principal dimensions	11
1.1.2 Displacement and weight	11
1.1.3 Motorization	11
1.1.4 Electrical installation	11
1.1.5 Tank capacities	11
1.1.6 Fixing point for cranes, resting-points for slipping and transport	11
1.2 General arrangement	12
1.2.1 Rigging plan	12
1.2.2 Deck arrangement	13
1.2.3 Accommodation plan	14
1.3 Drive system	15
1.3.1 Sails	15
1.3.2 Rigging	15
1.3.3 Motorizing, engine room, gear, propeller	15
<u>2. Installations and circuits</u>	17
2.1 Tanks and piping – water	17
2.1.1 Fresh water, drinking water – cold	17
2.1.2 Sea-water circulation	18
2.1.3 WC-installation, waste holding tank	18
2.2 Tanks and piping – fuel	19
2.3 Steering gear	19
2.3.1 Description of the system	19
2.3.2 Rudder blade and rudder bearing	19
2.4 Bilge pump, bilge lines	20
2.4.1 Description of the pumping arrangement	20
2.5 Electric installation	21
2.5.1 AC-installation	21
2.5.2 DC-installation	21
2.5.3 Operating the installation and specific features	21
2.5.4 Important warnings on the DC-installation	22
2.5.5 Important warnings on the AC-installation	22
2.5.6 Distribution of electric devices	23
2.5.7 Wiring plans	25
2.5.8 Wiring distribution plans	26
2.5.9 AC-distribution	27

	page
2.6 LPG installation	29
2.6.1 The components	29
2.6.2 Operation	29
2.7 Fire protection	30
2.8 Anchor	31
2.9 Engine cooling system	32
2.10 Exhaust gas system	32
2.11 Ventilation/Airing	32
2.12 Board ducts, sea water valves	33
<u>3. Environmental protection</u>	34
3.1 Fuel and oil	34
3.2 Waste	34
3.3 Sound	34
3.4 Swell	34
3.5 Exhaust gas	34
3.6 Antifouling, coatings	34
3.7 Varnish remover	34
<u>4. Maintenance</u>	35
4.1 Maintenance, cleaning	35
4.2 Wearing- and spare parts	36
4.3 Repairs	36
4.4 Winter storage	36
-	
<u>5. Final remarks and notes</u>	38
<u>6. List of manuals supplied</u>	39

Introduction

This manual will help you to handle your yacht safely and with pleasure. Apart from information about the yacht itself and installed or additionally supplied fittings the manual also contains information on operation and maintenance. Please familiarise yourself with everything before you go on your first voyage.

If this is your first yacht or if you are not really familiar with the special characteristics of a motor yacht please make sure you get proper training before you put it into operation. Do not hesitate to contact the dealer or our shipyard for information about further training possibilities.

As the scope of supply depends on the order, the equipment of your yacht can deviate with some descriptions and illustrations. In order to be able to adapt our yachts to the constantly progressing technical standard, we must reserve ourselves changes in form, equipment and technology. For these reasons no requirements can be derived from all data, illustrations and descriptions in this manual.

**PLEASE KEEP THIS MANUAL IN A SAFE PLACE
AND HAND IT OVER TO THE NEW OWNER IF YOU SELL THE YACHT.**

BAVARIA would like to welcome you to the circle of **BAVARIA** owners and would like to thank you for placing your confidence in our products by acquiring this yacht.

Your contract partner and the management and staff of Bavaria Yachtbau GmbH hope you will enjoy your new yacht.

Bon voyage, fair winds and fine weather.

BAVARIA Yachtbau GmbH
Management



W. Herrmann

Category of design

Following the European Recreational Craft Directive each boat has to be classified according to a category of design.

All sailing yachts of BAVARIA belong to the category of design A,

designed for extended voyages where conditions may exceed wind force 8 (Beaufort scale) and significant wave heights of 4m and above, and vessels largely self-sufficient.

Certification

Actually the EC Directive intends for yachts of this size the certification module Aa only. That means that the manufacturer certifies the correspondence of construction and equipment with the Directive itself but stability and buoyancy is checked by another notified body.

IMCI (International Marine Certification Institute) from Bruxelles was put into charge as a notified body (see: Declaration of Conformity).

Identification



The hull identification was formed into the transom on starboard side. This is a unique sequence of digits and letters. It is

DE-BAV

Builder's plate

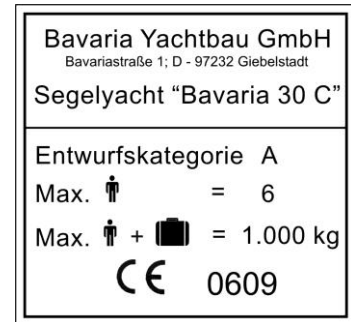
The builder's plate on the front wall of the cockpit is a demand of the Directive because certain information are required which will be explained in the following.

**Explanations**

- **Category of design A :** Ocean
- **Max.  =6:** Maximum number of persons recommended by the manufacturer if the yacht is situated in the sea area corresponding to the category of design. The number of crew can be increased under consideration of the maximum additional loading capacity if the yacht is on a voyage in non-ocean areas.
- **Max  +  = 1000 kg:** Maximum additional loading including 6 persons, stores, provisions and personal equipment (excluding tank capacities).
- **CE 0609:** CE marking which indicates the conformity of the yacht with all provisions of the Directive. The sequence of digits is the code number of the certifying body, in this case the **IMCI (International Marine Certification Institute)** (see: Declaration of Conformity).

Warnings

Many chapters of this manual will support a trouble free operation, maintenance or draw your attention to signs of dangers. To find them more easily they are especially marked (in boxes or in bold). We advise you to study them carefully although the experienced skipper might be quite familiar with many of them.

The following chapters contain such warnings/notes or other important information for operating the yacht.

**Danger**

Means, that an extreme real hazard which will lead to the death or too irreparable injuries with great probability exists if no adequate precautions are found.

**Warning**

Means, that a hazard which can lead to injuries or death exists if no adequate precautions are found.

**Caution**

Means that a memory of safety measures or the attention judges on handling, which can be unsure or lead to personal injuries or to harm of the vessel or from components.

**Declaration of Conformity - Recreational Craft – Sound and Construction
Directive 94/25/EC as amended by 2003/44/EC**

Name of the manufacturer: Bavaria Yachtbau GmbH

Street: Bavariastr. 1 Town: Giebelstadt

Postost Code: 97232 Country: D – Deutschland (Germany)

Name of Authorised Representative (if applicable): _____

Street: _____ Town: _____

Postost Code: _____ Country: _____

Name of Notified Body for **construction** (if applicable): IMCI

Street: Rue Abbé Cuypers 3 Town: Bruxelles

Postost Code: 1040 Country: Belgique ID Number: 0609

Examination report / Certificate number: BB0AV030 Date: (yr/month/day) 2005 / 07 / 25

Name of Notified Body for **sound** (if applicable): _____

Street: _____ Town: _____

Postost Code: _____ Country: _____ ID Number: _____

Examination report / Certificate number: _____ Date: (yr/month/day) ____ / ____ / ____

Module(s) used for construction: A Aa B+C B+D B+E B+F G H

Module used for sound: A Aa G H

DESCRIPTION OF THE CRAFT

Identification Number Craft

D	E
---	---

B	A	V	G	3	0	-	-	-	-	-	-
---	---	---	---	---	---	---	---	---	---	---	---

Brand name of the craft: Bavaria

Type of craft:
 sailboat motorboat
 inflatable
 other (specify): _____

Type of hull:
 monohull multihull
 other (specify): _____

Construction material:
 aluminium, aluminium alloys plastic, fiber reinforced plastic
 steel, steel alloys wood
 other (specify): _____

Design Category: A B C D

Max. Recommended engine power: 58 kW

Length of hull: 9,32 m Beam of hull: 3,29 m Draught: 1,85/1,40 m

Type or number: 30 Cruiser

Propulsion:
 sails petrol engine
 diesel engine electrical motor
 oars
 other (specify): _____

Type of engine:
 outboard inboard
 z or sterndrive without integral exhaust
 z or sterndrive with integral exhaust
 other (specify): _____

Deck
 decked partly decked
 open
 other (specify): _____

I declare at my own and sole responsibility that the craft mentioned above complies with all applicable essential requirements in the way specified (and is in conformity with the type for which above mentioned EC type examination certificate has been issued) – include text between brackets only if such certificate has been issued.

Name: W. Hermann
 (identification of the person empowered to sign on behalf of the manufacturer or his authorised representative)

 Signature and title: _____
 (or an equivalent marking)

Date: (yr/month/day) 2011-03-08

Essential requirements (reference to relevant articles in Annex 1 of the Directive)	Harmonised standards used	ISO-standards used	Other normative documents used	See the technical file
General requirements (2)	8666			
Hull Identification Number – HIN (2.1)	10087			
Builder's Plate (2.2)	14945			
Protection from falling overboard and means of reboarding (2.3)	15085			
Visibility from the main steering position (2.4)				
Owner's manual (2.5)	10240			
Integrity and structural requirements (3)				
Structure (3.1)	12215			
Stability and freeboard (3.2)	12217			
Buoyancy and floatation (3.3)	12217			
Openings in hull, deck and superstructure (3.4)	12216, 9093 9093			
Flooding (3.5)	11812 12116 12217 15083			
Manufacturer's maximum recommended load (3.6)	14946			
Liferaft stowage (3.7)			RCD	
Escape (3.8)	9094 12216			
Anchoring, mooring and towing (3.9)	15084			
Handling characteristics (4)	8665 11592			
Engines and engine spaces (5.1)				
Inboard engine (5.1.1)	16147			
Ventilation (5.1.2)				
Exposed parts (5.1.3)				
Outboard engine starting (5.1.4)				
Fuel system (5.2)	7840 9094 10088 11812 16147			
General – fuel system (5.2.1)	10088			
Fuel tanks (5.2.2)		21487		
Electrical systems (5.3)	9097 10133 13297 28849			
Steering systems (5.4)	10592			
General – steering system (5.4.1)	13929 28847 28848			
Emergency arrangements (5.4.2)				
Gas systems (5.5)	10239			
Fire protection (5.6)				
General – fire protection (5.6.1)	9094			
Fire-fighting equipment (5.6.2)	9094			
Navigation lights (5.7)			COLREG/CEVNI	
Discharge prevention (5.8)	8099			
Annex IC – Sound Emission	14509			



INTERNATIONAL MARINE CERTIFICATION INSTITUTE

International Non-Profit Association

Rue Abbé Cuypers 3 / B-1040 Bruxelles / Belgique / +32 2 741 6836 / +32 2 741 2418
www.imci.org / info@imci.org

EXAMINATION REPORT

We hereby certify that the product below manufactured by

Bavaria Yachtbau GmbH

Bavariastr. 1 - D-97252 GIEBELSTADT - GERMANY

BAVARIA 30 CRUISER

Recreational Craft

Scope	Design & Construction
Boat type	Sail
Boat design category	A
Module type	Aa
Length of hull [m]	9,32
Beam of hull [m]	3,29
Loaded displacement mass [kg]	5600
Maximum rated engine power [kW]	58
Number of persons recommended	6
Recommended load [kg]	1000
Certificate number	BBAV030

*meets the requirements of the Recreational Craft Directive
94/25/EC as amended by 2003/44/EC in accordance with the
Essential Safety Requirements 3.2 for Stability and Freeboard and
3.3 for Buoyancy and Flotation*



Ulrich Heinemann
Ulrich Heinemann (Managing Director)
for EU - Notified Body : 0609

2005-07-25

This certificate is valid for boats identified by the CIN as a
2006 model

References to the relevant standards used are given on the Declaration of Conformity



NBN EN 45011 accredited organisation - Certificate No 070 PR

1. Description of the yacht

1.1 Main particulars

1.1.1 Principal dimensions

Length overall	L_{OA}	9,45 m	Length of hull	L_H	9,32 m
Length on waterline	L_W	8,25 m	Breadth max.	B max	3,29 m
Draught - normal keel	D_{max}	abt. 1,85 m	Draught - flat keel	D_{max}	abt 1,40 m
Headroom (without antenna and similar things)			H_D	abt	14,10 m
Headroom (for transport)			H_T	abt	3,60 m

1.1.2 Displacement and weights

Weight of the empty yacht -incl. safety equipment	4 200 kg
Weight of the fully equipped yacht- ready for sailing with crew	5 600 kg
Ballast	1 000 kg

1.1.3 Motorization

Diesel engine:

Manufacturer Volvo Type	D1-20, 13 kW
Cooling	indirect (sea-/fresh-water)
Reverse-reduction gear Saildrive	130 S reduction ratio 2.19:1
Propeller: 2-bladed fixed propeller made from an aluminium alloy (Option folded propeller)	

1.1.4 Electrical installation

220/110 V (option) AC-installation

Shore connection (option)	socket CEE-plug; current operated	230 V earthed socket
Battery charger (option)	230 V AC / 12 V DC with 27 A max. current (option)	

12 V DC-system

1 x engine battery 12 V 55 Ah	1 x bord battery (option 2 x) 12 V 140 Ah
Motor generator (alternator)	battery charger

The distribution occurs about switchboard, electric circuits with thermal safety switches, LED display, rocker switches and voltmeters with changeover switch.

1.1.5. Tank capacities

1 fresh water tank	abt 150 l	on port side below the aftcabin berth.
1 fuel tank	abt 90 l	on starboard side in the locker seat.
1 holding tank (option)	abt 40 l	on starboard side behind bathroom.
1 gas cylinder	abt 3 kg cylinder (Butane)	in cockpit

1.1.6. Fixing points for cranes, resting-points for slipping and transport



Attention

The rear webbing will be placed in the area of the sail drive.



1.2 General arrangement

1.2.1 Rigging plan

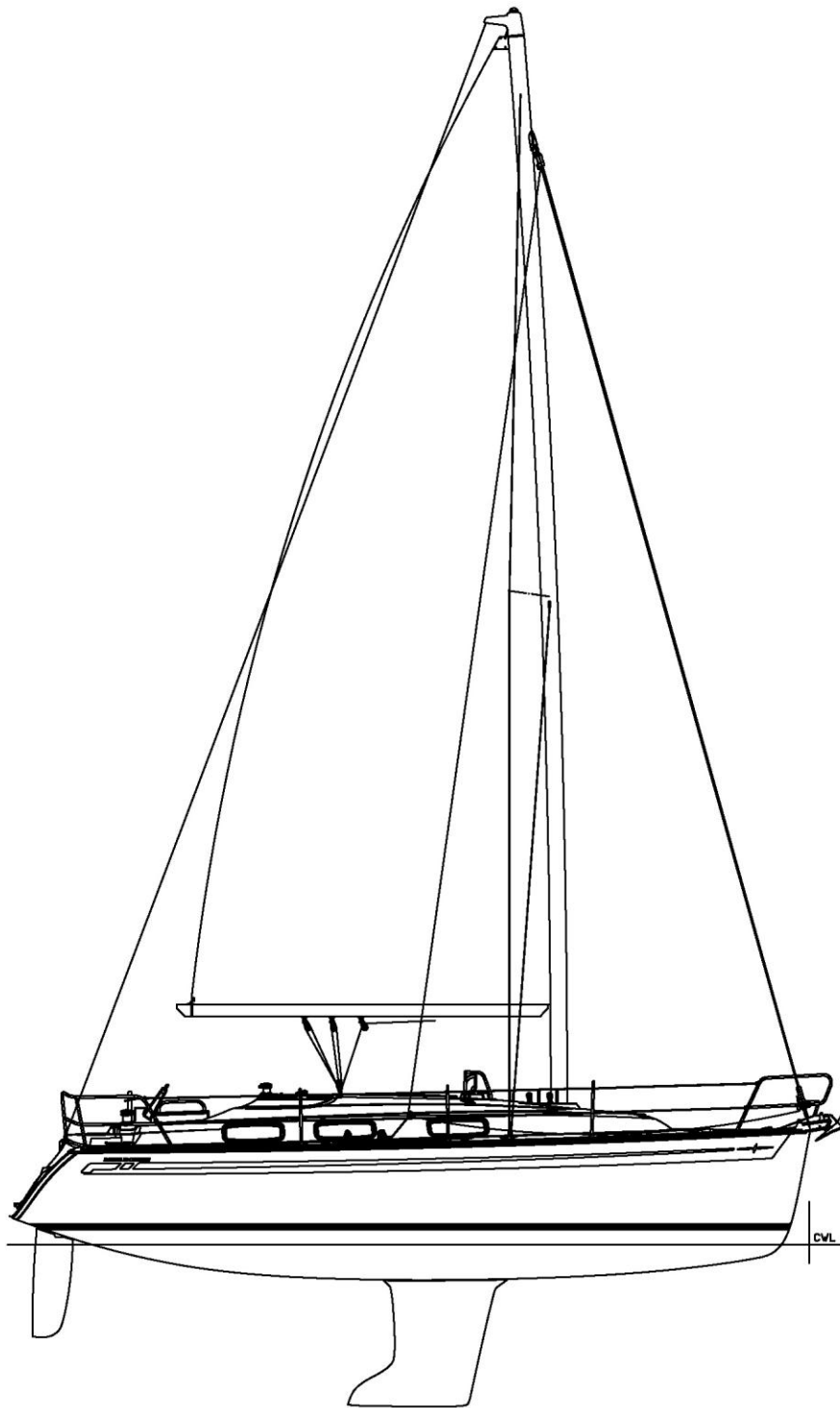

Reference

The valid measuring of the foresail reefing gear are on the enclosure note at the carton of the Furlex-foresail reefing gear.

1.2.2 Deck arrangement

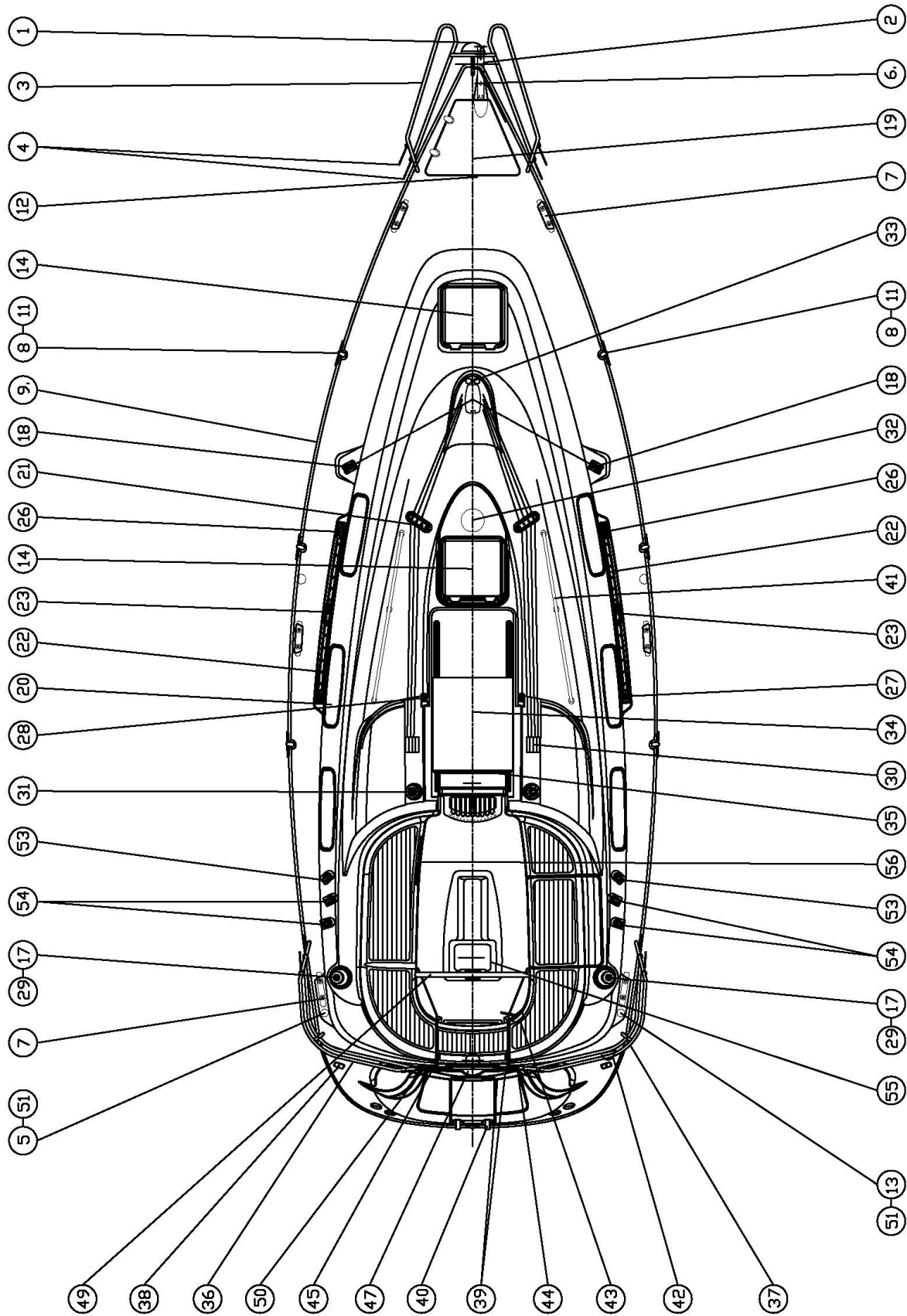

	DESCRIPTION	BESCHREIBUNG
1	Bow navigation light	Zweifarbeleuchte
2	Bow fitting	Bugbeschlag
3	Bow pulpit	Bugkorb
4	Life lines	Relingsdurchzüge
5	Water inlet	Wasser Einfüllstutzen
6	Anchor chain bail	Ankerkasten
7	Mooring cleats	Belegklampe
8	Stanchion	Relingstütze
9	Toe rail	Fussreling
11	Stanchion base	Relingfuss
12	Spin. boom vang padeve	Deckauge
13	Fuel inlet	Diesel Einfüllstutzen
14	Op. hatch	Vorschiffsluke
15	Op. hatch	Vorschiffsluke
16	Fixed hatch	Festluke
17	Spinnaker winch	Spinnakerwinde
18	Main shrouws	Wantenpütting
19	Electric windlass	Elektrische Ankerwinde
20	Opening port light	Portlight
21	Deck organizer	Umlenklöke
22	Genoa track	Genoaschiene
23	Genoa track car	Genoaschlitten
24	Main sheet track	Grossschotschlitten
25	Main sheet track car	Grossschotschiene
26	Front end stop (g. track)	Schienenendstück
27	Aft end stop (g. track)	Schienenendstück mit Umlenkbloken
28	Putting for main sheet	Pütting für Grossschot
29	Winch	Genoawinde
30	Stopper	Stopper
31	Winch	Fallwinde
32	Ventilator	Decklüfter
33	Cable penetration	Kabeldurchführung
34	Sliding hatch	Schiebeluke
35	Washboard	Steckschott
36	Aft port pushpit	Heckkorb links
37	Aft starboard pushpit	Heckkorb rechts
38	Backstay chain plate	Achterstagpütting
39	Aft pushpit life line	Strektau mit Pelikanhaken
40	Boarding ladder	Badeleiter
41	Grabrails	Handreling
42	Stern light	Hecklaterne
43	Hand operated bilge pump	Handlenzpumpe
44	Shore socket 230 V	Steckdose 230 V
45	Engine ventilation inlet	Belüftungsroste
47	Tiller	Pinne
49	Steering wheel	Steuerrad
50	Shower	Cockpitdusche
51	Tank venting	Tankentlüfter
53	Footblock with lock off	Liegender Block mit Stopper
54	Cheek block-port/starbord	Liegender Block Back/Steuerbordseite
55	Engine panel	Motorinstrumententafel
56	Cockpit port light	Cockpit Portlight

1.2.3. Accommodation plan

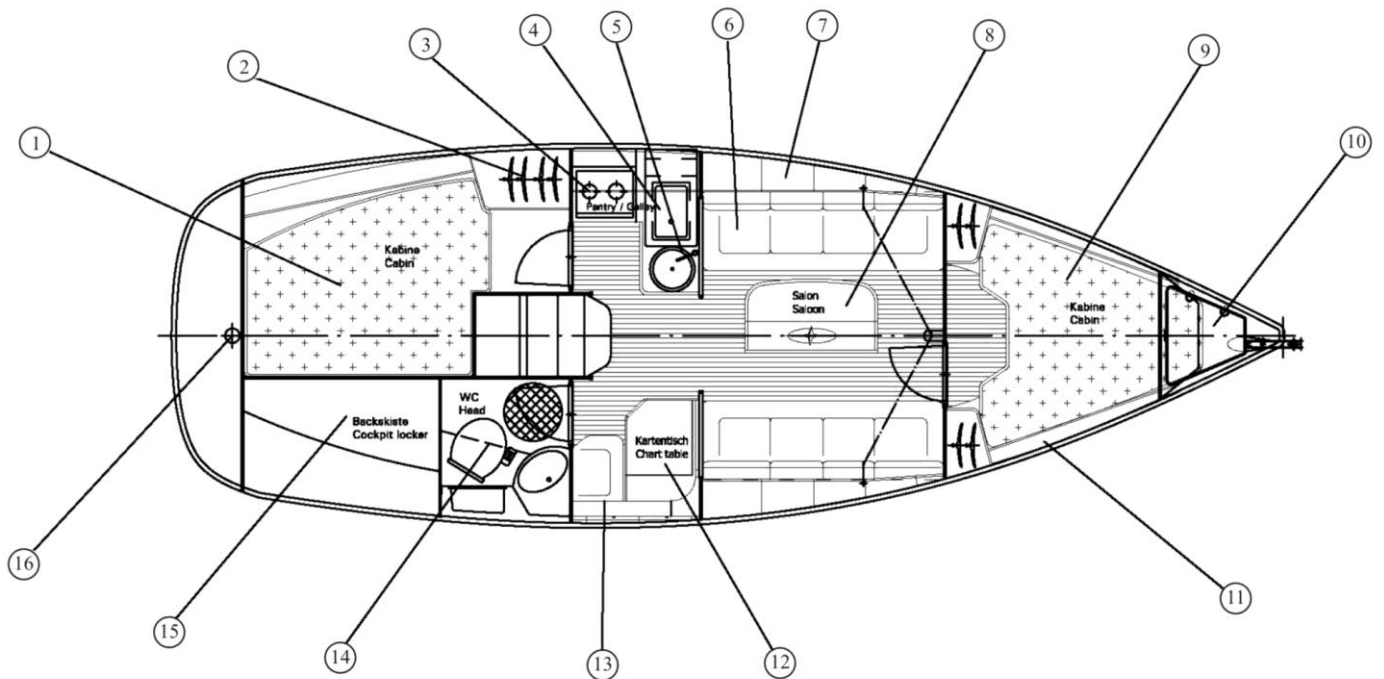

	Description	Beschreibung
1	Double berth	Doppelbett
2	Hanging locker	Kleiderschrank
3	Gas cooker with oven	Gasbackofen
4	Refrigerator	Kühlschrank
5	Sink	Spüle
6	Seating	Sitzgruppe
7	Book locker	Bücherschapp
8	Saloon table	Salontisch
9	Double berth	Doppelbett
10	Anchor locker	Ankerkasten
11	Shelf	Hängeschrank
12	Chart table	Kartentisch
13	Electrical switch panel	Elektrische Schalttafel
14	Head	WC
15	Cockpit locker	Backskiste
16	Steering gear	Rudernanlage

1.3 Drive systems

1.3.1 Sails

The SY Bavaria 30 is equipped with the following standard sails:

Main sail - standard	abt 24,20 sqm
Main sail - fully-battened	abt 24,20 sqm
Main sail " - mast reefing gear	abt 21,00 sqm
Furling Genoa	abt 24,60 sqm

1.3.2 Rigging

Mast length: 12525 mm; Length of boom: 4250 mm; Length of spreaders: 755 mm/ 1105 mm

Mast

- LM- Profile, without taper; - 27 deg. double spreaders , angular; - 2 halyards, topping- and boom lifts,
- Tipping line and fittings.

Boom

- LM-Profile; - clew outhaul; - 2 reefing lines; - eye for mainsheet; - eye for tipping line.

Standing rigging (made of 1x19-lace, material 4401), consisting of:

forestay with excessive footage (headsail reef system)			1x
intermediate shroud	2x	permanent backstay	1x
lower shroud	2x	permanent backstay –bridle	1x
upper shroud	2x	permanent backstay tackle	1x

Running Rigging

Inside the mast:

- | | |
|-------------------------------|--------------------------------|
| - Main halyard | Option: |
| - Genoa halyard | - Spinnaker halyard (attached) |
| - Boom lift | - Spinnaker uphaul |
| - 3 additional tripping lines | - Spinnaker downhaul |

Inside the boom: 2 revving lines (battened sail); 1 clew outhaul

Additionally we refer to the enclosed trim instructions of the manufacturer.



Caution

Before of every sail:

- Test strings, cordage, lanyards and split pins.
- Safeguard the split pins through adhesive tape or bending.
- Transpose deformed or damaged bolts.

1.3.3 Motorizing, engine room, gear, and propeller

This yacht is equipped with a inboard diesel engine with a sail-drive gear and a fixed propeller (Option: folded propeller).

The engine room is separated from living quarters by plywood-bulkheads covered with sound-insulating material. An access is possible through:

- a shutter below the companion way,
- detachable bulkhead in the aft cabin beside the engine room

Cooling-water supply to the engine is realised via the saildrive-gear.

Engine plant

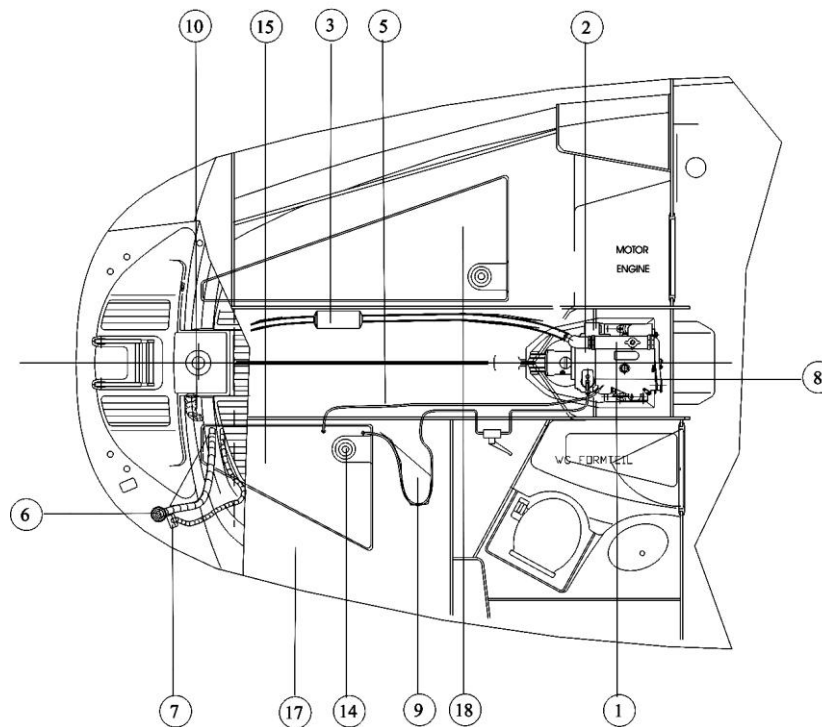
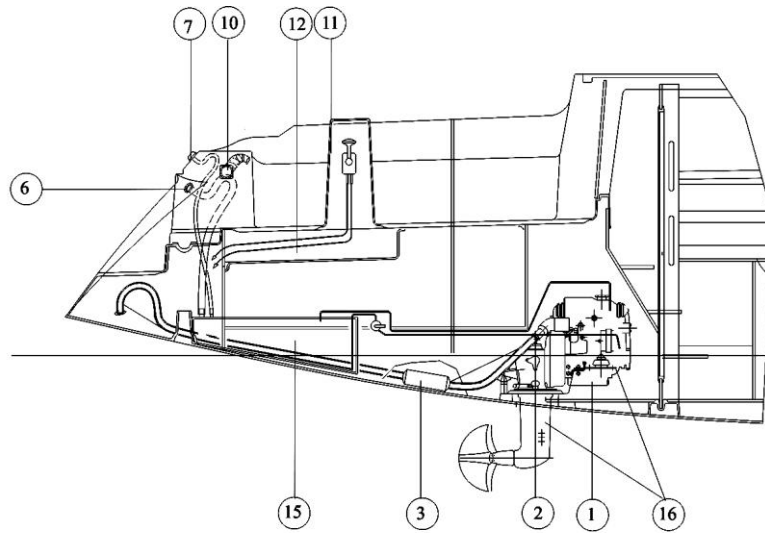

1	Engine Volvo	Motor Volvo
2	Engine exhaust system	Motorauspuffsystem
3	Exhaust water lock	Auspuffwassersammler
4	Engine fuel inlet	Kraftstoffeinfüllstutzen
5	Feed back fuel	Kraftstoffrückführung
6	Fuel tank filling hose	Diesel-Einfüllstutzen
7	Fuel tank ventilator	Tankentlüfter
8	Fuel filter	Kraftstoff-Filter
9	Fuel cock	Kraftstoffkugelhahn
10	Ventilator grille	Belüftungsroste
11	Engine panel	Motorinstrumententafel
12	Engine control cables	Motorfernbedienungskabel
13	Ventilator engine	Motorbelüftungsroste
14	Fuel gauge	Vorratgeber Kraftstofftank
15	Fuel tank	Dieseltank
16	Engine cooling water	Motorkühlwasser
17	Locker seat	Backskiste
18	Fresh water tank	Frischwassertank

2. Installations and circuits

2.1 Tanks and piping - water

2.1.1 Fresh water, drinking water –cold

The yacht has a water tank in the aft with a capacity of 150 l. Fresh water is supplied via a water inlet (with a blue cover) at the transom, port side. You can take water from the tank over a hose connection leading to the pressure water-pump. This pump, establishing the complete cold water circulation, is fitted below the pantry. An interruption of the operation of the pressure pump is done by cutting off all ducts. All pipes/hoses should be checked for leaks if the pump continuous working though all ducts were cut off properly. The pump is protected by a filter which should be regularly checked and cleaned if necessary.

Components:

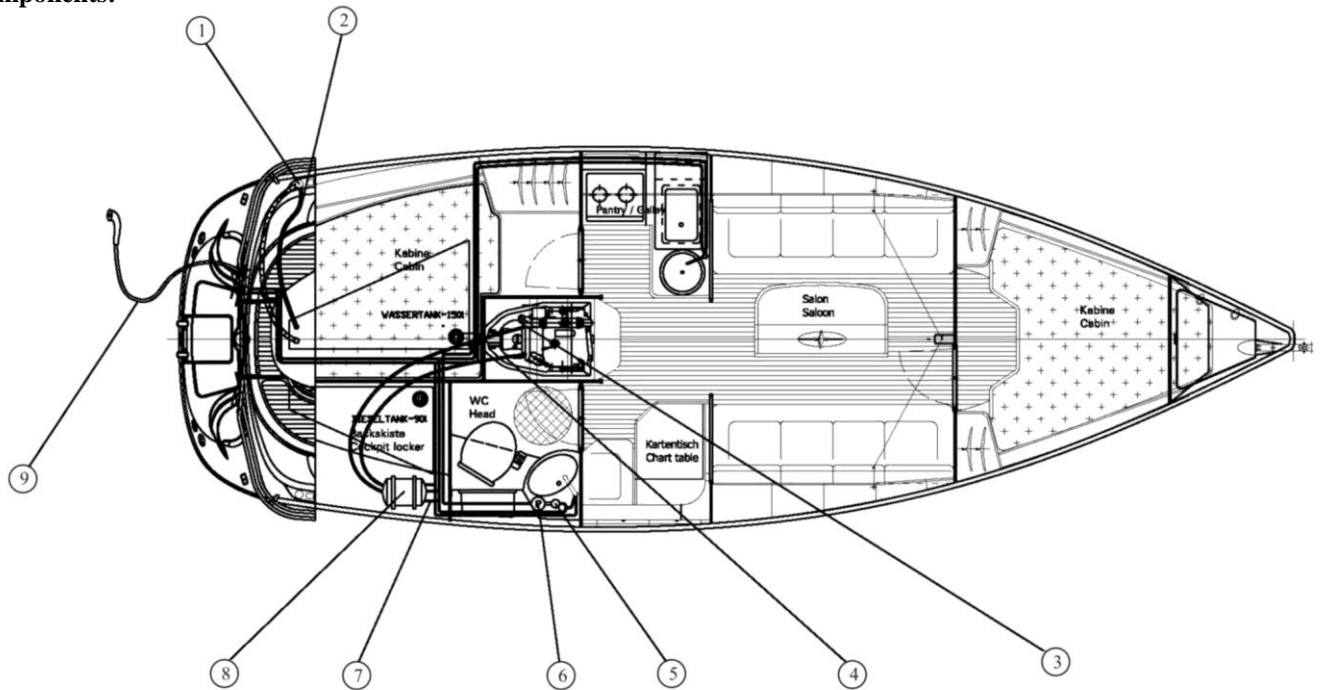

1	Deck plate (inlet)	Einfüllstutzen
2	Tank venting	Tankentlüftung
3	Engine circular	Motorkreislauf
4	To drain the water heater	Zum Entleeren des Boilers
5	Accumulator tank + pressure switch	Druckgefäß + Drückschalter
6	Fresh water pump	Frischwasserpumpe
7	Reflux water heater	Rücklauf Boiler
8	Water heater	Boiler
9	Cockpit shower	Cockpitdusche



Note

Exchange the water in tank from time to time.
Additionally you should use common purifiers.

2.1.2 Sea-water circulation

Sea-water is necessary for both WC flushing and engine cooling (see: 2.9).

2.1.3 WC –installation: see enclosed directions for use



Attention

If you are not aboard for a longer time you should close all sea-valves.

Components: WC-flushing

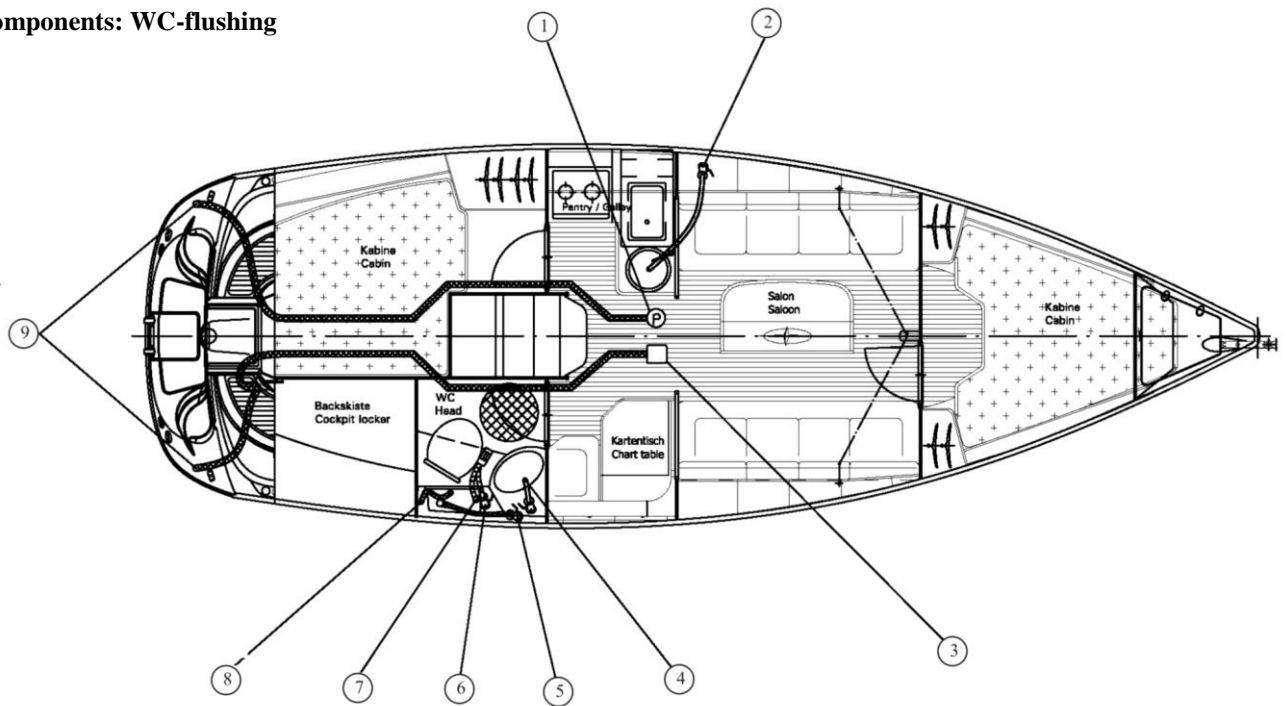

1	Electrical bilge pump	Elektrische Lenzpumpe
2	Sink drain valve	Kugelhahn-Ausgang Spüle
3	Hand operated bilge pump	Handlenzpumpe
4	Sink drain valve	Kugelhahn-Ausgang Spüle
5	Waste-water drain valve	Kugelhahn-Ausgang Fäkalientank
6	Toilet-water inlet valve	Kugelhahn-Eingang WC
7	Toilet drain	Ausgang WC
8	Waste-water tank venting	Fäkalientankentlüftung
9	Outlets	Borrdurchlässe

2.2 Tanks and piping - fuel

Storage tank

There is a 90 l plastic diesel tank with an inspection opening on starboard-side below the aft berths. It is filled via a fuel inlet with a red cover (marked with FUEL) at the transom of the yacht. The tank pickup is situated on the tank. The supply is made of a fire-proof fuel hose according to ISO 7840. The vent line is led to above deck.

Supply of the engine

The engine is supplied via a suction pipe from the upper edge of the tank. Due to the short distance a fire proof fuel pipe is used. This is led via a wide-meshed filter/ water separator, fuel pump and fine filter to the engine and then back to the tank.



Attention

A trouble free operation of the engine and heating is only possible, if the fuel is clean. That's why a regular inspection and cleaning of filter/water separator is unavoidable.

The fuel tank should be completely emptied and cleaned once a year.



Warning

When refilling the tank:

- Switch off the engine, heating and stove!
- Do not smoke or use open lights!



Attention

If there is a danger of fire:

- Close the fuel stop valve immediately!

2.3 Steering gear

2.3.1 Description of the system

The rudder is a suspended, balanced hydrofoil midship rudder. It is operated by hand from the steering wheel at the steering post in the cockpit. Transmission of power is realised by means of rope pulls and fairleads to the rudder quadrant. With the autopilot (option) an electric motor installed.

2.3.2 Rudder blade and rudder bearings

The rudder blade is a profiled one. It consists of a FRP-body. The rudder post is made of a sea-water resistant aluminium alloy and is laminated into the blade. The post runs in two easy-going and special rudder bearings. The rudder is fixed by a mounting clip at the upper end of the post that also serves for the keeping of the rudder tiller.

The mounting clip is additionally secured with a straight stud bolt on the rudder post.



Attention

Check regularly and repair if necessary tight hold of the mounting clip on the rudder post.

The rudder bearings used by **BAVARIA YACHTBAU** are self-setting bearings. Since rudder bearings are subject to wear and tear they should be inspected and maintained regularly.

Emergency tiller

The emergency tiller is stored in the starboard locker seat.

In case of emergency remove the steering wheel, the rudder quadrant for rope pulls and the quadrant for the auto pilot (option).

The emergency tiller to be mounted and secured at the top of the tiller wheel.



Attention

Please ensure a suitable bearing lubrication of the necessary parts of the rudder installation with water-proof lubricants (or Teflon).

Bearing clearance has to be avoided and can be adjusted at the top bearing.

The post must have no clearance but should not need heavy movements.

The steering wheel got a built-in brake, which you can fasten. Make always sure that this brake is not tight especially when sailing with the auto pilot. This would mean an overload for the electric motor.

The socket of the steering gear is integrated into the deck's form. On the socket there is the casing of the wheel hub. A chain is laid over a tooth-wheel of the hub. Both the rope pulls are run from the rudder quadrant via fairleads to the ends of this chain, where they are fixed crosswise by means of wire-rope grips, protected with an elastic covering.

Each end of the rope pulls has one shroud adjuster each fixed at the rudder quadrant. It is recommendable to check these ropes from time to time and to retighten if necessary.

2.4. Bilge pumps, bilge pipes

The chain locker is made watertight towards the yacht. It is self-bailing through two holes in the skin.

All **BAVARIA** yachts have got a self-bailing cockpit. The drain wells are placed at the rear and lowest part of the cockpit and are led outboard through the transom with hoses.

2.4.1 Description of the pumping arrangement

The yacht is equipped with both a manual pump and an electric bilge pump. The main line bilge suction has a capacity of 75 l/min.

A draw bucket is an ideal means for bailing out water. It should always be ready in a cockpit seat locker.

**Attention**

Close all sea valves if you leave your yacht for a longer period. Valves being not clearly visible, like e.g. in the toilet room, should only be opened before use and closed short after.

**Warning**

In a serious situation, e.g. in case of a heavy inrush of water as a consequence of a collision, the pumping capacity might not be sufficient. Take measures for damage control with collision mats or other suitable means.

**Note**

In case of spherical valves a transverse lever-direction indicates: CLOSED
And a longitudinal ones means: OPEN

Maintenance note

The tightness of ducts should be inspected regularly.
Retighten all hose clips and the stuffing boxes of valves

Components of the bilge pumping installation:

See pic 2.1.1.

2.5 The electric installation**2.5.1 The AC-installation**

The yacht has got a shore connection (option) by which it can be supplied with electric power from ashore when being berthed in a port. The plug box (meeting the CEE-norm) is installed at the transom of the yacht. The power is supplied into a shore connection unit, placed under the chart table.

The plug box is operational as soon as the shore supply cable has been plugged in. It only serves the operation of electric machines.

2.5.2 The DC-board net

All electric devices aboard are supplied with the 12 V DC. A main-switch is installed in the electric panel at the chart table. Power distribution is effected by a switchboard above the chart table. The lettering next to each switch refers to the corresponding consumer. You can find all the switches for the 12 V consumers at the switchboard. By this you can operate different consumer-groups, being marked with logos or lettering, separately. Some of the switches are designed for an installation of additional electric devices. There are only automatic fuses used. So you only have to press them in case of a breakdown. If a fuse blows repeatedly you should spot the cause or consult a specialist (electrician).

2.5.3 Operating the installation and specific features

The combination of an AC- with a DC installation offers a clearly higher comfort but requires some special knowledge.

Charging the batteries

All batteries are maintenance-poor and drain-protected. They are charged via a buffer diode by the motor-generator. Charging the starter battery always takes priority to ensure a safe start of the engine.

AC-consumers

The only fixed link is the one to the battery charger. The safety contact plug-box at the electric panel is designed for electric tools to be used for small repair work.

DC-consumers

The essential consumers are:

- navigation lights
- engine displays
- VHF-radio wiring (option)
- devices for comfort
- bilge pumps
- tank display
- electronic devices

Navigation lights have absolute priority. In case of a lack of capacity all other consumers have to be switched off first. By a stand-by operation of the engine, even when under sail, the batteries can be brought up rather quickly. After a while you can switch on the other consumers again.

2.5.4 Important warnings on the DC-installation**Attention**

You should never

- work at the electric installation if it is in operation,
- alter fuses or overload switches,
- change the electric wiring and/or wiring plans; this has to be done by specialists only,
- install electric devices or add parts that exceed the allowed load limit,
- leave the yacht unattended with the electric installation in operation. This does not go for automatic bilge pumps, fire protection and –alarm devices.
- As long as the diesel engine is in operation, you must not disconnect the 12 V charging circuit.

Before starting a voyage you should always check

- the battery voltage,
- the correct function of navigation lights .

Have spare lamps for all navigation lights aboard.

2.5.5 Important warnings on the AC-installation**Attention**

- The electric wiring of the yacht and/or corresponding wiring plans must not be changed.
- Service and maintenance must be carried out by a qualified specialist.

Warning

To avoid the danger of a rush of current or fire :

- The shore connection cable must never hang into water.
- Plug the shore connection cable first aboard and then ashore.
- Do not alter plugs of shore connection cables

Disconnecting the shore connection cable:

First disconnect the shore connection cable ashore and then aboard.

	Description	Beschreibung
1	Navigation light	Zweifarbennleuchte
2	Windlass	Elekt. Ankerwinde
3	Windlass switch	Ankerwinde - Bedienteil
6	Fresh water gauge	Vorratgeber für Frischwassertank
7	Through - hull echo sounder	Echolot - Geber
8	Through - hull log	Sumlog - Geber
10	Ceiling light	Deckenleuchte
11	Fresh water pump	Druckwasserpumpe
12	Shower drain pump	Duschpumpe
13	Shower pump switch	Duschpumpenschalter
14	Bilge pump	Elektrische Lentzpumpe
15	Batteries	Batterie
	Engine battery 55 A	Motorstromkreis-Batterie 55 A
	Bord battery 140 A	Bordstromkreis-Batterie 140 A
16	Battery charger	Batterieladegerät
17	Electric panel	Elektro Panel
18	Main switch	Batterie-Hauptschalter
19	Auto pilot (optional)	Autopilot
20	Electronic compass	Elektronischer Kompass
22	Engine start	Anlasser
24	Water heater	Boiler
25	Stern Light	Heckleuchte
26	Shore socket 230 V	Landanschluss 230 V
27	Fuel gauge	Vorratgeber für Kraftstofftank
28	El. refridgerator	El. Kühlschrank
29	Mast lights (navigation light)	Kabeldurchführung
30	Reading light	Kartentischlampe
31	Speaker	Lautsprecher
33	Neon lamp	Neonlampe
34	Air heater (optional)	Heizungsfühler (Option)
35	Air heater - pump diesel (optional)	Heizung Pumpe Diesel (Option)
36	Air heater-thermostat (optional)	Heizung Thermostat (Option)

2.5.7 Wiring plans

Stücker	Sicherung	PN	Bezeichnung
1	1	12	Toplicht
1	2	9	Dampferlicht
1	3	6	Beleuchtung Bug
1	3	3	Beleuchtung Heck
1	4	1	Salingleuchte
1	5	5	Innenbeleuchtung
1	5a	2	Innenbeleuchtung
1	6	10	Innenbeleuchtung
1	6a	7	Innenbeleuchtung
1	6b	4	Innenbeleuchtung
2	7	12	Instrumentenbel.
2	7	7	H1 Blatt 2 0,25
2	8	9	Navigationsinstr.
2	9	6	Funk
2	10	3	Ankerwinde
VL	11		Bilgenpumpe
2	12	11	FW-Pumpe
VL	13		Duschabsaugpumpe
VL	14		
2	15	8	Heizung
VL	16		Kühlschrank
17			12V-Steck Dose
2	10		12V-Steck Dose
2	18	5	Reserve
2	19	2	Reserve
VL	20		Reserve

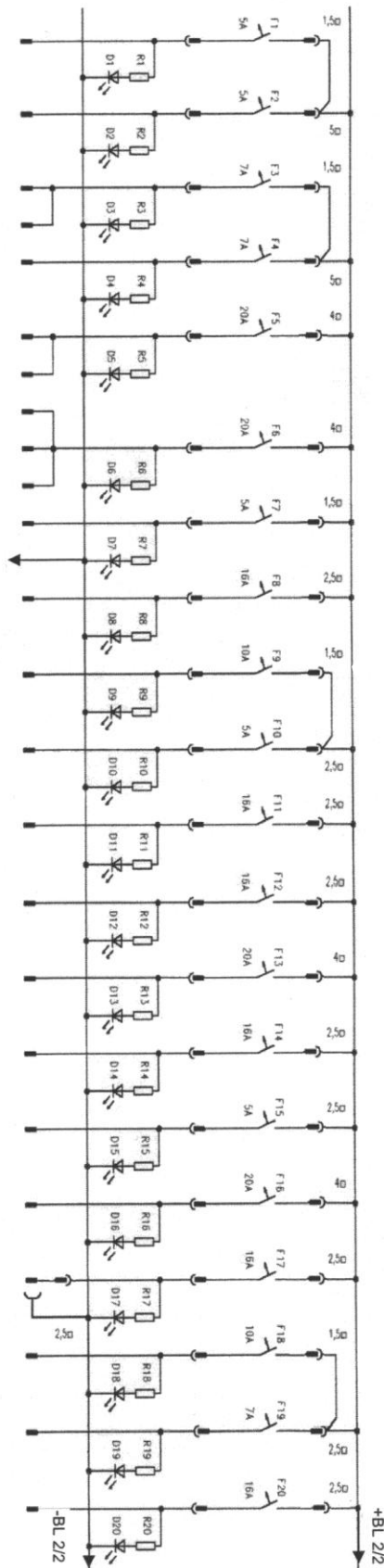

English	Deutsch
Plug	Stecker
Fuse	Sicherung
Designation	Bezeichnung
Toplight	Toplicht
Steaming light	Dampferlicht
Bow light	Beleuchtung Bug
Stern light	Beleuchtung Heck
Crosstrees light	Salingleuchte
Interior lighting	Innenbeleuchtung
Instrument lights	Instrumentenbel.
Navigation instruments	Navigationsinstr.
Radio	Funk
Anchor windlass	Ankerwinde
Bilge pump	Bilgenpumpe
Fresh water pump	FW-Pumpe
Self priming shower pump	Duschabsaugpumpe
Heating	Heizung
Refrigerator	Kühlschrank
Plug socket 12V	12V-Steckdose

2.5.9 AC-distribution



Anschlußplan
Panel 202 / 230Volt~



Art.-Nr. PL0103-202 V3 BAV

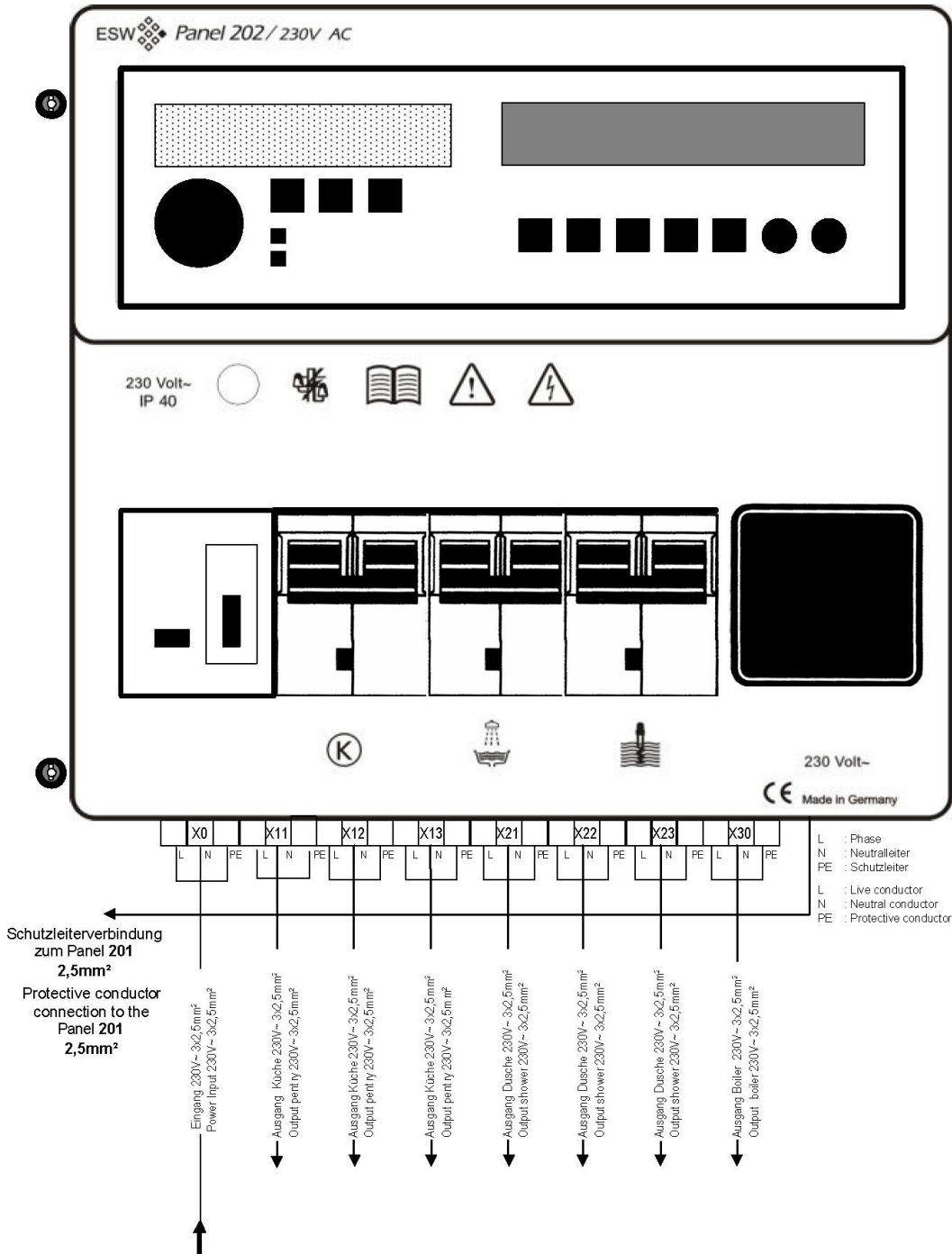



Connection diagramm
Panel 203 / 120Volt AC



Art.-Nr. PL0103-203 BAV

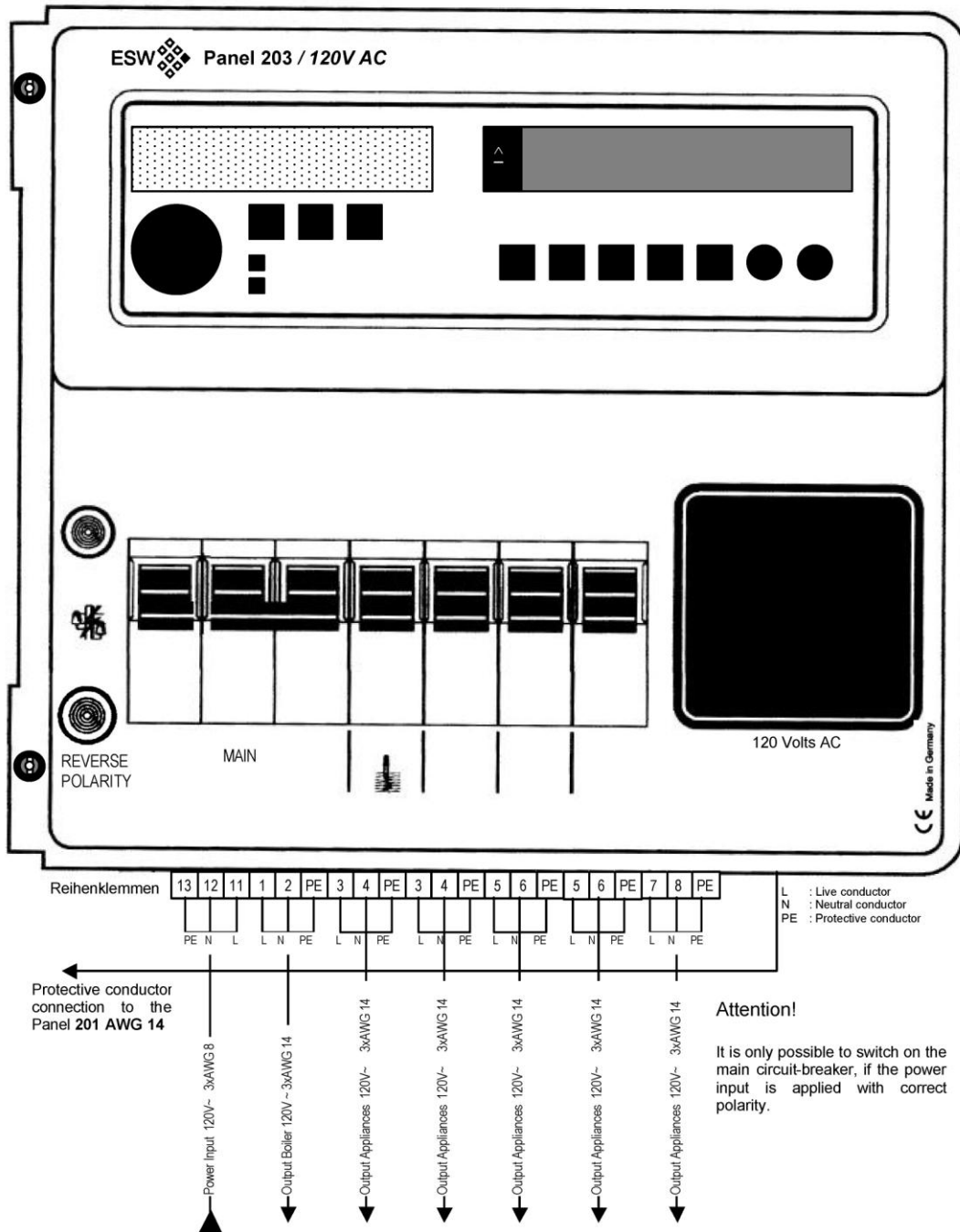

2.6 L.P.G. installation

The gas installation for the stove meets the European norm EN 10239. The test-certificate is attached.

The gas pipe leading to the stove from the standard 3 kg-gas cylinder is an 8 mm copper pipe. It is placed into a self-bailing casing moulded into the deck in the rear cockpit area. All gas pipes have been installed according to the German safety regulations. The best-by date for the soft connection hoses between the gas cylinder and the copper pipe and between copper pipe and stove is printed onto the hoses. They have to be replaced after the expiry date.

The reducing valve in the gas cylinder casing has a service pressure of 30 mbar. The flow rate is 1 kg/h.

2.6.1 The components

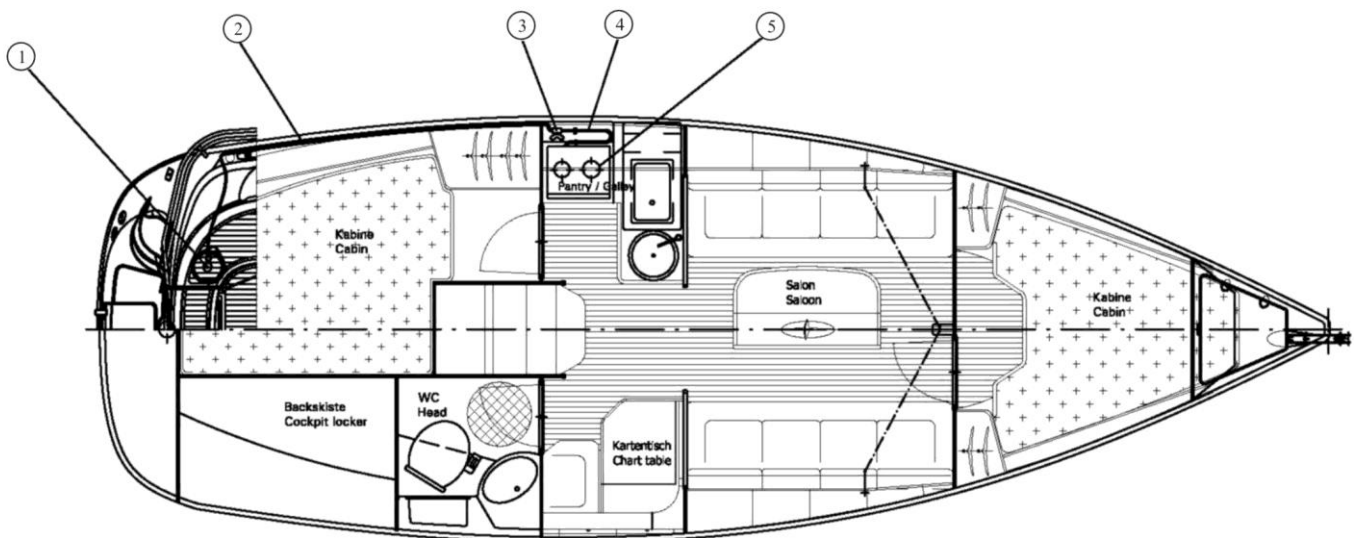

1	Gas tank with valve	Gasflasche mit Reduzierventil
2	6/8 Copper tube	Kupferrohr 6/8
3	Gas stop cock	Gaskugelhahn
4	Rubber hose	Gummischlauch
5	Gas stove with ove	Kocher mit Backofen

2.6.2 Operation

Gas installations require care. That's why you should follow this sequence:



Attention

- Open the stop valve in the gas cylinder casing
- Open the valve before the stove
- Open a stove valve and lighten the gas
- Keep the valve open until the glow timer allows further burning.



Attention

For finishing follow the same (above mentioned) sequence from the valve in the gas cylinder casing to the stove valve to allow all gas in the piping to escape and burn.



Attention:

- Do not use liquids containing ammonia for checking the pipe.
- Never handle with open light and do not smoke when looking for a leakage or connecting a new gas cylinder.

And here is some more advice on how to prevent difficulties with the gas installation:

- Close all gas valves if the stove is not in use. In a case of emergency you should close the valves immediately.
- The stove valves have to be closed before the gas cylinder valve is opened.
- Check the L.P.G. installation for possible leakages regularly. Check all connections with soap suds or the like (for doing so the stove valves have to be closed – all other valves of the installation have to be open).
- If you find any leakages close all valves and have the installation repaired by a specialist before further use.
- Since the flames consume oxygen a proper airing and de-aeration is necessary. Do not use the stove for heating the cabin.
- Valves of empty gas cylinders have to be closed and disconnected from the installation. Have the covers ready.
- Do not use the gas cylinder casing for storing other equipment.
- Never leave your yacht unattended if the stove is in use.
- Check the hose pipes at least once a year. Have them replaced if necessary.
- If you install a new stove make sure that it has got the same working pressure.
- Check the exhaust gas pipes at least once a year. Replace them if they are defective.

2.7 Fire protection

When building the yacht special attention was paid to avoid the risks of fire. This includes the choice of materials, the distance of stove flames to the surrounding built-in furniture and an island position of the engine. The engine room has got a lining with fire resistant insulating material.

As the owner of the yacht you should keep this state and pay attention to the following advice:

**Attention:**

- Keep the bilge clean and check regularly if there is a smell of fuels or gas.
- Do not have any freely suspended curtains above or close to the stove or other devices with open fire.
- Inflammable material must not be stored in the engine room. If you store non-inflammable materials in the engine room make sure that they are protected against falling into the engine installation or are in the way.

Furthermore you and your crew can support fire protection if you follow the following advice:

**Never**

- obstruct any exits or hatches.
- alter safety installations like fuel- and gas valves and electric switches and the like.
- leave the yacht unattended if the stove or the heating is in use.

Never

- use gas lights in the yacht.
- fuel the tank or replace gas cylinders if the engine is running or if the stove or heating is used.
- smoke or use open lights while handling with fuel or gas.

The well-known sources of danger on board are

- the stove in the pantry and
- the engine room.

If, despite all precautionary measures, a fire should break out aboard, there are three fire extinguishers a board which are fixed at the following places:

Nr. 1 and 2: **Powder extinguisher** in the starboard locker seat, at least fire grade 10A/68B

Nr. 3: **Powder extinguisher** at the mess tables foot, at least fire grade 10A/68B

Additionally you should place in the pantry a light **fire retarding cloth**, which is made of glass cloth and is very useful in the case of fire caused by overheat fat.

It is the yacht owners duty

- to have all fire extinguishers regularly checked and maintained ;
- to have fire extinguishers replaced after the expiry date. The same goes if the extinguishers should have been used. The new extinguishers should at least have the same capacity as the discussed ones.

It is the yacht owners or skippers duty

To make sure that

- all extinguishers are freely accessible
- to inform all persons on board about:
 - the position and use of all fire extinguishers and the fire retarding cloth,
 - the position and function of the opening for the extinguishers nozzle in the engine room bulkhead,
 - the exit through the escape hatch above the fore-berths.



Caution

Test the fire extinguishers regularly!
Train yourself as regards fire fighting.
Always obey seaman's duty!

2.8 Anchor-, towing- and warping facilities (option)

The bower anchor (plough anchor), about 17 kg, hot-galvanised, (is known for its high holding power). It lays ready-to-fall in an anchor stowage device and is secured with a bolt. The chain (option) has a length of 50 m and a nominal thickness of 8 mm. It is run out by an electric anchor windlass (option) operated with a remote control. The remote control is placed in the chain locker before use and its function is activated at the switch board.

Furthermore it is recommendable to have a stern anchor as well as sufficient mooring- and towing lines with the necessary strength on board.

1 stern folding anchor (4-fluke grapnel anchor) , 12 kg, hot-galvanised, fixed at the aft guard-rail. 6m chain forerunner, thickness 7 mm, 34 m polyamide anchor rope, 18 mm, 3-strand hawser laid. It is stored in the port transom seat.

The rope is cleated aft.

2.9 Engine cooling system

Engine cooling

The engine has got a two-circuit cooling system. Water enters through the saildrive, is led to the heat exchanger and then injected into the exhaust gas pipe. Together with the exhaust gas the cooling sea water is exhausted via the silencer and the exhaust pipe at the stern. This guarantees a trouble-free engine operation. Moreover the engine noise is reduced.

All hose connections of the system are secured with double stainless steel clips.



Attention

- Check and clean the sea water filter in regular intervals, depending on the water quality.
- Before starting the engine make sure that the cooling water inlet is open.
- Have a short look into the engine room for possible leakage.
- When the engine is running it is highly recommendable to check regularly if cooling water is escaping with the exhaust gas.

2.10 Exhaust gas system

The yacht is fitted with a "wet" exhaust gas system, i.e. cooling sea water is injected into the exhaust gas elbow causing a cooling of exhaust gases. This mixture is led down into a silencer/water lock, runs through a pipe in the locker seat on the starboard side of the aft cabin, is led upwards at the stern and escapes to the side above the water-line.

The exhaust gas hose consists of a synthetic rubber material with an integrated steel spiral.

The hose is heat-resistant (for some time) and should be checked and replaced if necessary.

A constant flow of sea water has to be guaranteed. The hose is secured at its joints with two clips.

If there is an interruption of the sea water flow, the temperature sensor in the exhaust gas hose will release a visual and acoustic warning. In this event you should stop and switch off the engine immediately until the problem has been settled (see manual of the engine manufacturer).



Attention

A regular inspection if saltwater comes out of the exhaust is urgently advisable.

2.11 Ventilation/Airing

We have taken the following measures for a proper ventilation of all rooms:

Chain locker

Certain ventilation is achieved through the hawser port in the cover of the chain locker and through its bilge holes.

Living cabins/ Salon and forward quarter

One ventilator

Aft cabin

1 side light /bull's eye showing to the cockpit

Components:

1 deck ventilator, 4 side lights,

2.12 Board ducts, sea water valves

Openings below the water line are possible weak spots. That is why we pay special attention to them.

All board ducts in the underwater part, with the exception of the duct for the transmitter of the echo sounder, consist of brass-made screwed joints with spherical sea valves and hose nipples. All hose connections are secured with two clips each.

For the cockpit drain special plastic joints are used.



Attention

Close all sea valves if you leave the yacht for a longer time. Valves being not clearly visible, like e.g. in the toilet room, should only be opened for use.



Maintenance note

The tightness of board ducts should be inspected regularly.
Check and retighten all hose clips and stuffing boxes of valves if necessary.



Note

In case of spherical valves a transverse lever-direction indicates : CLOSED
And a longitudinal direction means: OPEN.

Board ducts:

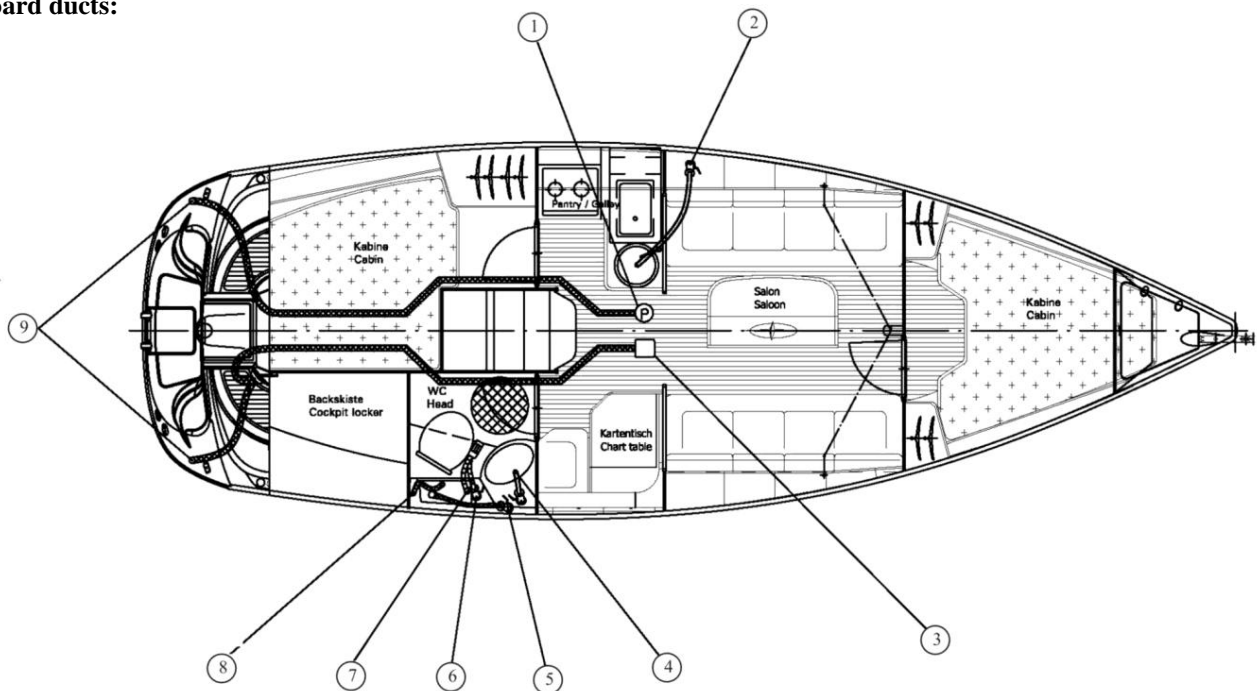

1	Electrical bilge pump	Elektrische Lenzpumpe
2	Sink drain valve	Kugelhahn-Ausgang Spüle
3	Hand operated bilge pump	Handlenzpumpe
4	Sink drain valve	Kugelhahn-Ausgang Spüle
5	Waste-water drain valve	Kugelhahn-Ausgang Fäkalientank
6	Toilet-water inlet valve	Kugelhahn-Eingang WC
7	Toilet drain	Ausgang WC
8	Waste-water tank venting	Fäkalientankentlüftung
9	Outlets	Borrdurchlässe

3. Environmental protection

BAVARIA YACHTBAU has already met the legal requirements referring to exhaust gas regulations with its choice for the inboard diesel installed. An exhaust gas type-examination certificate can be handed in or sent on later.

3.1 Fuel and oil

You should be especially careful when filling the tank. A (wet) cloth around the fuel inlet can prevent fuel from dripping into water. In your engine manual you can also find a diagram with a curve about the specific fuel consumption thus offering you some good hint on the most favourable engine speed.

For a necessary exchange of oil you should use a suction pump, because you cannot drain it off like a car. The oil has to be exchanged at least once a year, even in case of a little operation time of the engine.

A well-maintained engine should never leak. But in order to prevent even smallest amounts of oil being discharged overboard with the pumped out bilge water, the engine bed has been designed in form of a closed oil sump. All water from this sump, being possibly mixed with oil, has to be pumped into a separate canister and has to be deposited ashore.

In any case there should be oil-binders aboard.

3.2 Waste

For all water sportsmen it goes without saying: waste is not thrown overboard. This is also true for biodegradable waste. There should be a regular waste bag or -bin in a locker seat.

3.3 Sound

The wet exhaust pipe of the diesel engine reduces the engine sound considerably. Additionally rubber bearings, elastic couplings and the engine room insulation minimise sound emissions. Nevertheless you should not turn up the engine too quickly and, please, reduce the engine speed in waters with dense traffic.

3.4 Swell

Natural bank areas are sensitive against swell. Please keep sufficient berth. Formation of waves, caused by your yacht, is an indicator of where and when you should reduce your speed to avoid unnecessary swell. Pay attention to relevant signs.

3.5 Exhaust gas

Check the escaping exhaust gas regularly. The exhaust gas should show neither black smoke nor blue clouds. In such a case you should either clean the air filter or have a repair shop readjusted the engine.

3.6 Antifouling coatings

The underwater part of the hull of each yacht has to be protected with an antifouling coating because marine growth means more energy for propulsion. Today there is a wide range of protective paint with various effects for different bodies of water. Trust the recommendations of specialists for your decision. Coatings that are effective for years without any grinding in between are especially recommendable.

But if the coating has to be sanded to some extent you should arrange these activities with the port officials. Generally the ground under the yacht has to be covered with some plastic cloth to collect the rubbed down dust and dispose it.

3.7 Varnish removers

Most varnish removers contain aggressive substances and should not be used or as little as possible. A mechanical removal of paint is the much better way.

4. Maintenance

4.1 Maintenance, cleaning

1. Mast and rigging

See: Notes of the manufacturer

2. Sails

The sails are made of Dacron. This material is very robust and resistant. Thus the sails keep their form for a very long time.

Inspect all your running and standing rigging carefully for sharp edges, splints, protruding ends of wire and the like because laminated cloth is especially sensitive against touching them. Those parts of the cloth that can chafe at spreaders or shrouds should be protected on both sides by sticking self-adhesive cloth to them. The same goes for the foot of the sail if there is the possibility of chafing at the rails.



Note:

- Please remember: Damage to the cloth is mainly caused if it is incorrectly treated or handled. Especially if you let it shake, expose it to UV rays constantly or store it improperly.
- If there are any questions on the cloths do not hesitate to contact the manufacturer or your sail maker.
- Never remove track cars with ball bearings from the tracks carelessly. Always use sheet tracks with end stops.

Cleaning

Please clean your yacht immediately after you have taken it out of the water. High pressure cleaning devices will remove any growth. This is followed by an up keeping of the surface of the yacht. All paint manufacturers provide detailed instructions for their coating systems.

For ships sailing in salt waters: remains of salt absorb water and can cause a faster corrosion. Where- and whenever it is possible you should rinse the yacht and parts of it with fresh water.

Care and maintenance of teak decks

Untreated teak weathers to a natural silver-grey colour, with no detriment to the timber's strength or other mechanical/physical properties. Because of teak's inherent durability and weather-resistant properties, the use of protective paints or coatings is neither necessary nor advisable.

Practical tips on care and maintenance:

Protective wood care oils – penetrate deep into the timber, and under the influence of heat and moisture can adversely affect the adhesion of the caulking material to the sides of the joint. As a result, the seal between the caulking material and the sides of the joint may break down, allowing water to enter.

Paints and lacquers are decorative coatings which, when applied to a teak deck, dry to form a continuous film over the caulking material as well. Some paints will not dry properly where they come into contact with the caulking material, leaving the surface tacky. In time most paints will flake away along the line of the joint. This spoils the appearance of the teak deck and causes cracks to open up along the joints.

Teak cleaners should be used only if they contain no other active ingredients apart from normal soap. Additives such as phosphoric or oxalic acid, which are often incorporated as brighteners, are corrosive substances which attack both the caulking material and the timber, causing them to age rapidly.

We therefore recommend that teak decks be swabbed down with a mop and clean fresh water, to which a small quantity of normal soap may be added if desired. Heavy soiling may be removed by scrubbing with a hard sponge. The use of a power washer is not recommended. The *high-pressure water jet* will remove areas of sapwood and break the seal between the caulking material and the sides of the joint.

In extended periods of hot, dry weather teak decks should be watered at regular intervals to prevent the timber from drying out completely. Excessive loss of moisture will cause the timber to shrink, placing the joints under stress. Under unfavourable conditions this can lead to premature ageing or failure of the joint seal.

Stainless steel

The corrosion resistance of all fittings is based on their ability to constitute a thin skin together with the air oxidant, which makes a positive electrical potential. Specialists call it a CR-passive (CR is standing for chrome). But chrome is in the galvanic contact series negative and a bit less valuable than iron. If the thin protection skin is damaged the stainless CR will be active and less good than pure chrome. The corrosion can start.

Who is not disappointed about little brown spots on the fittings? They are caused by flying rust or particles of iron, which are in the air and in all harbours placed near big towns. As soon as the flying rust settles onto the protective coat of the stainless steel, it destroys the CR-passivity very aggressively and fast.

Stainless steel only stays good looking for a long time, if it is taken good care of it.

Make it your habit to also clean the rail stanchions, pulpits and push pits and all stainless fittings thoroughly too if you are washing your boat with clear water. Clear water will wash away the salt, rust and flying rust, the protective coat will be "ventilated" and its function is guaranteed again.

If you have already brown spots, you can use most of all available metal cleanings to take care of the stainless steel fittings or you take normal polish like you use it for the hull.

Of course – all the best care can not help, if in the first place the fittings are not made out of the right material or the stainless steel has not been treated correct. Before you will buy the fitting, ask for example if the fitting has been polished electrical.

4.2 Wearing- and spare parts

As an experienced skipper you will not have difficulties in getting original spare parts. If you need any help, please contact the yard.

If you need any spare parts but cannot get the original ones you have to pay attention to the stability values to keep the yacht at the high technical standard it used to have at the time of delivery.

4.3 Repair work

In need of repair of the hull you may consult a reliable workshop. The interior construction was designed in such a way that a non-destructive elimination of defects can be realised.

In regard to the technical equipment you may contact a reliable work shop or the shipyard, too.

4.4 Winter storage

We have already given some well-directed advice on winter storage in different paragraphs of this manual. Generally speaking all firms offering winter storage should meet the latest technological standard as far as environmental conditions, storage blocks, fire protection and accessibility of your yacht is concerned. Moreover there should be fixed rules for work, done by the owner himself, to prevent any interference with other sportsmen.

If possible the following objects should be taken from board and stored in a dry and frost-free place:

- Ship's papers and other relevant documents
- Charts, books and instruments
- Mattresses, upholstery, blankets and sleeping bags
- Sails and lines/ropes
- Foodstuffs
- Gas cylinders
- Safety equipment
- Life raft and rubber dinghy
- Batteries

Advice:

Before wintering you should pay special attention to the following parts and protect them correspondingly:

- Rinse and clean the transmitters of the speedometer and echo sounder.
- Maintain the electrical systems and clean them with suitable materials.
- Water pipes can be successfully cleaned with soft acids, e.g. white vinegar.
- Water valves should be taken to pieces and greased.
- The toilet and corresponding pipes are cleaned with fresh water.
- The rudder should be fixed that no movements are possible (e.g. by fixing the tiller or wheel).

Engine:

- Fill the fuel tank completely
- Exchange the propeller's sacrificial anode (if necessary).
- Empty all cooling-water of the engine and follow the instructions of the manufacturer.
- Slacken all belts (lighting engine and other engine driven devices).

Winter storage

- Observe all notes in the engine manual.
- Store the fully charged batteries at a ventilated frost-free place.
- Grease the steering wire and –components
- Remove all water out of the ship and protect it against rainwater entering it.
- Replace all components which seem not to be reliable any longer.

Mast and rigging

It may not always be possible, but it is recommendable:

- Unship the mast,
- Refit all standing and running rigging,
- Inspect the cables and other wires,
- Inspect bolts, spanners and other tie points for possible fatigue of material or cracks,
- Rinse all aluminium parts with fresh water
- Rinse all lines/ropes with fresh water and store them in a dry place,
- Rinse and grease all guide rollers of the mast and the boom.

5. Final remarks and notes

This manual is in conformity with the directives of the harmonised European Norm EN 10240. Much of it might go without saying for you. Nevertheless we hope that dealing with the different chapters of this manual will help you to understand the technical systems and the ideas behind them. As already mentioned in the introduction, the purpose of this manual is to contribute to an unspoilt use of the yacht.

Among the things that are not dealt with are e.g. the personal safety equipment. This solely belongs to the responsibilities of the skipper. It goes without saying that there have to be means of rescue for all persons on board. But this also includes the procurement and maintenance of a life raft, of signalling means, a first-aid- as well as a tool-kit.

Since the European Recreational Craft Directive pays special attention to fire protection it shall also be mentioned, that fire extinguishers have to be maintained in regular intervals and that it belongs to the duties of a skipper to introduce his crew into their operation.

Those being prepared for an emergency are normally never involved. But just in case: the yacht is properly equipped for those situations with suitable means.

We are constantly working on further developments of our sailing yachts. We hope you will understand that we have to reserve the right to carry out changes as far as form, equipment and technology is concerned. For these reasons you cannot lay claim to a complete correspondence of your yacht with the information, figures and descriptions in this manual.

If your yacht should be equipped with any details not being referred to in this manual or in the owner's file, your party to the contract will inform you about the correct operation and maintenance.

Since all yachts, manufactured by **BAVARIA Yachtbau GmbH**, are exclusively sold by official dealers there is no contractual relationship between the yard and the customer/owner.

Thus **BAVARIA Yachtbau GmbH** is not familiar with details of the contract between the dealer and the customer. That's why it is not urgently necessary that your party to the contract takes over the full extent of our warranty conditions.

So, if you have to make a claim it is unavoidable to contact your party to the contract.

6. List of manuals supplied

- manual with declaration of conformity
- engine assurance board with corresponding operating instruction
- gas test document with corresponding working instruction
- release checklist
- leaflets and description of production work
- working instructions:
 - Hand operated bilge pump
 - Compass
 - Bilge pump
 - WC-instruction
 - Elapsed-time indicator

Proof of identity

(To be completed by the dealer or party to the contract)

- 1. First launch :
- 2. Date of delivery to the owner:
- 3. Type of boat:
- 4. Hull identification number:
- 5. Commission number:
- 6. Name of the yacht:
- 7. Manufacture and type of engine:
- 8. Engine number:
- 9. Gear (manufacture, type, gear ratio):
- 10. Propeller (manufacture, type, dim.):
- 11. Dealer, representative (name/address):
.....
.....
- 12. Signature/stamp dealer:

Please return signed to:

(Address of the dealer)

Acknowledgement of receipt

Name:

Address:

Owner of the yacht

BAVARIA 30 Cruiser
HIN DE-BAVG30

Signature: _____